

Engineering+

北京助工精密机械有限公司

电话：010-51920199 13581835480

网址：www.engineeringplus.cn



MOTOR SPINDLE OVERVIEW

瑞士IBAG电主轴



SMALL MOTOR SPINDLES 小尺寸系列电主轴

Ø 16mm - 60mm / HT 16 S 100 - HF 6015 D

				HT 16 S 100	HT 19 S 100	HT 22 S 100	HT 25 S 60	HT 25 S 100	HF 33 A 50	HF 33 A 60	HF 33 D/S 60	HT 33 D/S 60	HF 45 A 50	HF 45 A 60	HF 45.11 A 60	HF 45.11 S 35	HF 45 S 60	HF 45 S 80	HT 45 S 80	HT 45 S 140	HF 6015 D	
Speed 转速	Oil-air 油气润滑	C	RPM min ⁻¹	80'000	80'000	80'000	80'000	80'000														
	Grease 脂润滑	CP	RPM min ⁻¹	60'000	60'000	60'000	60'000	60'000	60'000	60'000	60'000	80'000	60'000	60'000	35'000	35'000	60'000	60'000	60'000	160'000	15'000	
	Max. speed* 最高转速	C	RPM min ⁻¹	100'000	100'000	100'000	120'000	90'000			80'000								90'000			
HF Asynchronous motor 异步电机	Power 功率	S6-40%	W						260	260	260	975	975	550	550	975	1300			530		
		S1-100%	W						200	200	200	750	750	475	475	750	1000			410		
	Torque 扭矩	S6-40%	Ncm						4.6	4.6	4.6	11.6	15.5	15	15	15.5	15.5			34		
		S1-100%	Ncm						3.5	3.5	3.5	8.9	11.9	13	13	11.9	11.9			28		
HT Synchronous motor 同步电机	Power 功率	S6-40%	W	208	273	312	182	351/364			520							2.500	819			
		S1-100%	W	160	210	240	140	270/280			400							1.900	630			
	Torque 扭矩	S6-40%	Ncm	2.5	3.1	4.7	2.0	4.9/6.5			6.2							38	5.6			
		S1-100%	Ncm	1.9	2.4	3.5	1.6	3.8/5.0			4.8							29	4.3			
Qty. of bearings 轴承数量				3	3	3	2	3	3	4	3	3	4	4	2/4	4	4	4	2	3		
Cone 刀柄接口	HSK	K																				
	SKI																					
	(B)BT / SK	B																				
	Capto	Y																				
	Collet 弹簧夹头	S	D6			ER8			P6		ER8	P9			ER11							
	Collet 弹簧夹头	U				Mega-3S									Mega-6S			Mega-4S				
Grinding arbor 磨轴锥柄	D									M4/Ø7								M6/Ø6.4				
Spindle Ø 外径		mm	16/17/18	19/20	22/22.8	25/25.4	25/25.4	33	33	33	45	45	45	45	45	45	45	45	45	60		
Spindle length 长度		mm	110.3	108.0	126.5	87.3	118.0	171.4	205.5	162.0	235.5	235.5	235.5	185.1	185.1	185.1	116.5	216.5				
Spindle weight 重量		kg	0.150	0.150	0.200	0.200	0.300	0.900	0.900	0.700	2.3	2.3	2.3	1.3	1.3	1.3	1.1	3.7				
Spindle cooling 主轴冷却			without* /无*													liquid /液态介质						
Options 可选项			P	P	E-P-U	E-P-U	E-P-U	P	H-P	P	P	P	P	P	P	P-U	P-U	P-U	P			
Encoder 编码器		V	OpenLoop/开环																			

*Small spindles with maximum speed are oil-air lubricated and have to be cooled. The heat must be dissipated via spindle holder. Maximum external housing temperature 60°C.

*小尺寸系列主轴在最高转速工作时，必须给予油气润滑及冷却。使热量通过卡具散出，确保主轴外表面最高温度不超过60°C



MEDIUM SIZED MOTOR SPINDLES 中尺寸系列电主轴

Ø 60mm - 150mm / HF 60 A/D/S 60 - HF 150 A 24 P

				HF 60 A/D/S 60	HT 60 A/D/S 60	HF 62 A 60 P	HF 62 A 70 P	HF 62 A 80 P	HF 80 A 20	HF 80 A/D/S 40	HT 80 A 40 **	HF 80 D 15 P**	HF 80 D 30 P	HF 100 A/S 40	HF 100 A/D/S 45	HT 100 A/D/S 45	HF 100 A/D/SI 50	HF 110 A 30	HT 110 A 30	HF 120 A/D/S 24 P	HF 120 A/D/SI 36	HT 120 A/D/SI 36	HT 120 A 72	HF 140 A/D/SI 30	HT 140 A/D/SI 30**	HF 150.2 A 24 P	
Speed 转速	Oil-air 油气润滑	C	RPM min ⁻¹	80'000					24'000	50'000				40'000	50'000		60'000	35'000			42'000	70'000	36'000				
	CC-grease 高速油脂	CCP	RPM min ⁻¹	70'000			70'000				50'000			38'000	45'000		45'000			30'000	32'000			25'000			
	Grease 脂润滑	C	RPM min ⁻¹	60'000	60'000	60'000	80'000	20'000	40'000	30'000	30'000	30'000	40'000	40'000	40'000	40'000	40'000	28'000	24'000			50'000	20'000	24'000			
HF Asynchronous motor 异步电机	Power 功率	S6-40%	kW	1.7	2.6	1.2*/2.0	1.3	1.7	2.5/3.2/4.3	1.5/1.7	7.8	4.8/7.8	5.8	10.5	7.8/16.9	7.8/16.9								18.2/32.5	18.2		
		S1-100%	kW	1.3	2.0	0.9*/1.5	1.0	1.3	1.9/2.5/3.3	1.15/1.3	6.0	3.7/6.0	4.5	8.0	6.0/13.0	6.0/13.0									14.0/25.0	14.0	
	Torque 扭矩	S6-40%	Nm	0.27	0.43	0.20/0.33	0.15	0.8	0.8	0.95/1.4	2.1	2.1/3.1	1.1	8.0	3.6/6.3	3.6/6.3								9.9/13.2	9.9		
		S1-100%	Nm	0.21	0.33	0.15/0.25	0.12	0.6	0.6	0.73/1.1	1.6	1.6/2.4	0.8	6.1	2.8/4.8	2.8/4.8									7.6/10.1	7.6	
HT Synchronous motor 同步电机	Power 功率	S6-40%	kW	4.2						4.3					9.1			18.2				19.2	9.1/15.0	28.6			
		S1-100%	kW	3.2						3.3					7.0			14.0				14.0	7.0/11.5	22.0			
	Torque 扭矩	S6-40%	Nm	0.57						2.1					5.4			15.6				15.6	2.6/4.8	23.4			
		S1-100%	Nm	0.43						1.6					4.1			12.0				12.0	2.0/3.7	18.0			
Qty. of bearings 轴承数量				4		2/3/4		3/4																			
Cone 刀柄接口	HSK	K							E32	C/E25 F32				C/E32 F40	C/E32 F40		E40 F50		C/E40 F50		E25	E40 A/C/E50 F63		A/T40			
	SKI		16						20					25										30			
	(B)BT / SK	B																30									
	Capto	Y																									
	Collet 弹簧夹头	S	ER16	P10	P9				ER16	ER25	ER20	D20			ER25									ER32			
Grinding arbor 磨轴锥柄	D	M10/Ø11						M10/Ø11	M10/Ø23/38		M16/Ø18	M10/Ø11		M22/Ø23									M22/Ø23				
SpindleØ 外径		mm	60	61.9	61.9	61.9	80	80	80	100	100	100	110	120	120	120	120	140/160	150								
Spindle length 长度		mm	216.5	249.5	239.5	239.5	323	298	263	332.5	332.5	298.5	460.9	380	380.5	309	419	475.5									
Spindle weight 重量		kg	3.7	4.4	3.7	3.7	7.3	7.3	7.1	13.8	11.1	12	24.1	21	22.5	28.5	31.8	44.3									
Spindle cooling 主轴冷却			liquid /液态介质				optional/可选				liquid /液态介质																
Options 可选项			H-I-P-V-W	P	P	P	F-G-H-K- P-W	F-G-H-I-K- Mn-P-V-W	P	F-G-H-I-K- Mn-P-V-W	F-G-H-I-K- Mn-P-V-W	F-G-H-I-K- Mn-P-V-W	B-F-G-H-I- K-P-V-W	B-F-H-I-K-P-V	F-G-H-I-I3-K- Mn-P-V-W	F-H-I-K-P-V	F-G-H-I-K- Mn-P- V-W	F-G-H-I-I3- R-P-V-W									
Encoder 编码器	V		optional/可选		OpenLoop/开环			optional/可选			optional/可选						CloseLoop/闭环										
*The heat must be dissipated via spindle holder. Maximum external housing temperature 60°C. / **Spindle motor with reduced speed. *主轴生热必须通过主轴夹具散热, 确保主轴外表面最高不超过60°C/**主轴电机降速处理																											



LARGE MOTOR SPINDLES 大尺寸系列电主轴

Ø 170mm - 360mm / HT 170 A 17 - HF 360 AI 7

				HT 170 A 17 P	HF 170 AI 18	HT 170 AI 18	HF 170 AI 20	HT 170 AI 20	HF 170 AI 22	HT 170 AI 22**	HT 210 A 20	HF 210 AI 24	HT 210 AI 24**	HF 220 A 24 P	HF 230 AI 17	HF 230 AI 18	HF 230 AI 20	HT 230 AI 20	HF 240 AI 12	HF 250 AI 12	HF 260 AI 12	HF 285 AI 10	HF 300 AI 10	HF 360 AI 7									
Speed 转速	Oil-air 油气润滑	C	RPM min ⁻¹		20'000		24'000		30'000		20'000		15'000		17'000		13'000		24'000		12'000		15'000		12'000		12'000		12'000		7'000		
	CC-grease 高速油脂	CCP	RPM min ⁻¹		17'000		22'000		22'000						15'000				20'000		13'000		13'000		10'000		11'000						
	Grease 脂润滑	C	RPM min ⁻¹	10'000	15'000		17'000		17'000					20'000	13'000			15'000		10'000		10'000		8'000		6'000							
HF Asynchronous motor 异步电机	Power 功率	S6-40%	kW		52.0/57.2		20.8/71.5		32.5/54.6		32.5		22.1		38.0		39.0/97.5		33.0		195/104.0		42.9		39.0/78.0		23.4/104.0		36.0		39.0		130.0
		S1-100%	kW		40.0/44.0		16.0/55.0		5.0/42.0		25.0		17.0		30.0		30.0/75.0		23.9		15.0/80.0		33.0		30.0/60.0		18.0/80.0		32.0		30.0		100.0
	Torque 扭矩	S6-40%	Nm		62.9/69.4		20.7/38.1		20.9/41.4		82.3		124.2		100.0		96.0/118.6		95.8		77.0/124.2		104.2		75.0/222.1		333.5/414.0		343.8		310.4		1'280.0
		S1-100%	Nm		48.4/53.4		16.1/29.3		16.1/31.8		63.3		95.5		79.0		73.8/91.2		72.6		59.0/95.0		80.2		57.7/170.8		256.6/318.0		305.6		238.8		985.0
HT Synchronous motor 同步电机	Power 功率	S6-40%	kW		52.0		39.0		39.0				71.5								27.3/72.8				52.0								
		S1-100%	kW		40.0		30.0		30.0				55.0									21.0/56.0				40.0							
	Torque 扭矩	S6-40%	Nm		99.3		124.2		74.5/86.6		41.4		189.0								174.0/231.7				275.9								
		S1-100%	Nm		76.4		95.5		57.3/66.6		31.8		145.0									134.0/178.3				212.2							
Qty. of bearings 轴承数量				4				4				4				5				4				5									
Cone 刀柄接口	HSK	K		A80	A/E63				A/C/E63				A/E63				A80	A/T63				A63	A100										
	SKI																																
	(B)BT / SK	B		40*				40*				40*				40/45/50				50	50												
	Capto	Y																		C6													
	Collet 弹簧夹头	S																															
Grinding arbor 磨轴锥柄	D		on request / 按用户要求																														
Spindle Ø 外径		mm	170	170	170/180	170	210	210	220	230	230	230	240	250	260	285	300	360															
Spindle length 长度		mm	629	624	520	405	580	506	543	620	690	600	750	764	786	1'450	812	988															
Spindle weight 重量		kg	70	85	63/70	44	118	118	125	152	165	145	230	240	250	275	305	345															
Spindle cooling 主轴冷却			liquid / 液态介质																														
Options 可选项			F-G-H-I-I3- Mn-P-V- WV-W	B-F-G-H-I- I3-K-Mn-P- R-V-W	B-F-G-H-I- I3-K-Mn-P- R-V-W	F-G-H-I- I3-K-Mn-P- V-W	B-F-G-H-I- I3-K-P-V	F-G-H-I- I3-K-Mn-P- V-W	F-G-H-I- I3-K-Mn-P- V-W	F-G-H-I- I3-K-Mn-P- R-V-W	F-G-H-I- I3-K-Mn-P- R-V-W	F-G-H-I- I3-K-Mn-P- R-V-W	F-G-H-I- I3-K-Mn-P- R-V-W	F-G-H-I- I3-K-Mn-P- R-V-W	F-G-H-I- I3-K-Mn-P- R-V-W	F-G-H-I- I3-K-Mn-P- R-V-W	F-G-H-I- I3-K-Mn-P- R-V-W	F-G-H-I- I3-K-Mn-P- R-V-W	F-G-H-I- I3-K-Mn-P- R-V-W	F-G-H-I- I3-K-Mn-P- R-V-W	F-G-H-I- I3-K-Mn-P- R-V-W	F-G-H-I- I3-K-Mn-P- R-V-W	F-G-H-I- I3-K-Mn-P- R-V-W	F-G-H-I- I3-K-Mn-P- R-V-W	F-G-H-I- I3-K-Mn-P- R-V-W	F-G-H-I- I3-K-Mn-P- R-V-W	F-G-H-I- I3-K-Mn-P- R-V-W	F-G-H-I- I3-K-Mn-P- R-V-W	F-G-H-I- I3-K-Mn-P- R-V-W	F-G-H-I- I3-K-Mn-P- R-V-W			
Encoder 编码器		V	CloseLoop/闭环																														

*the maximum allowed speed for tooling system (B)Bt / sK40 is 20'000 RPM./ **spindle motor with reduced speed.

*对于 (B) Bt/SK40刀柄接口的主轴最高允许的转速为20000RPM/**主轴电机降速处理



PLUG ,N` GO - MOTOR SPINDLES 快装式电主轴

HT 25 S 60 S - HFK 135 M/S 30

				HT 25 S 60 S	HFK 90.1 S 40	HFK 90 S 40	HFK 95.1 S 40 P*	HFK 135 M/S 30
Speed 转速	Oil-air 油气润滑	C CCP C	RPM min ⁻¹	80'000	60'000	60'000		40'000
	CC-grease 高速油脂		RPM min ⁻¹		58'000	58'000		
	Grease 脂润滑		RPM min ⁻¹	60'000	42'000	42'000	42'000	36'000
HF Asynchronous motor 异步电机	Power 功率	S6-40%	kW		22	3.0	1.3	10.4
		S1-100%	kW		1.7	2.3	1.0	8.0
	Torque 扭矩	S6-40%	Nm		0.43	0.48	0.3	5.6
		S1-100%	Nm		0.33	0.36	0.23	4.3
HT Synchronous motor 同步电机	Power 功率	S6-40%	kW	0.18				
		S1-100%	kW	0.14				
	Torque 扭矩	S6-40%	Nm	0.020				
		S1-100%	Nm	0.016				
Qty. of bearings 轴承数量				2	4			
Cone 刀柄接口	HSK	K						C32
	SKI							
	(B)BT / SK	B						
	Capto	Y						
	Collet 弹簧夹头	S		ER8	ER16	ER16	ER16	ER25
Grinding arbor 磨轴锥柄	D		on request / 按用户要求					
Spindle Ø 外径		mm	25/25.4	90	90	99	135	
Spindle length 长度		mm	87.5	259	259	217	348	
Spindle weight 重量		kg	0.200	7.1-8.6	7.1-8.6	4.4-5.7	21	
Spindle cooling 主轴冷却			Without/ 无	liquid / 液态介质		Air / 空气	liquid / 液态介质	
Options 可选项			E-U					
Encoder 编码器		V	Open Loop / 开环					
*Maximum external housing temperature 60°C. *主轴外表面最高温度不允许超过60°C								

瑞士 IBAG 电主轴
亚洲维修中心



维修区一角



电气测试区



动平衡机



电主轴锥孔专用磨床

The charts show only an extract of available motor configurations for IBAG motor spindles. Do you wish an alternative motor spindle or a customized solution? Feel free to contact us.

本手册所展示的电主轴仅是IBAG电主轴产品中的一部分，如您有特殊要求或者需要特殊设计的，请随时与我们联系，我们愿竭诚为您服务。

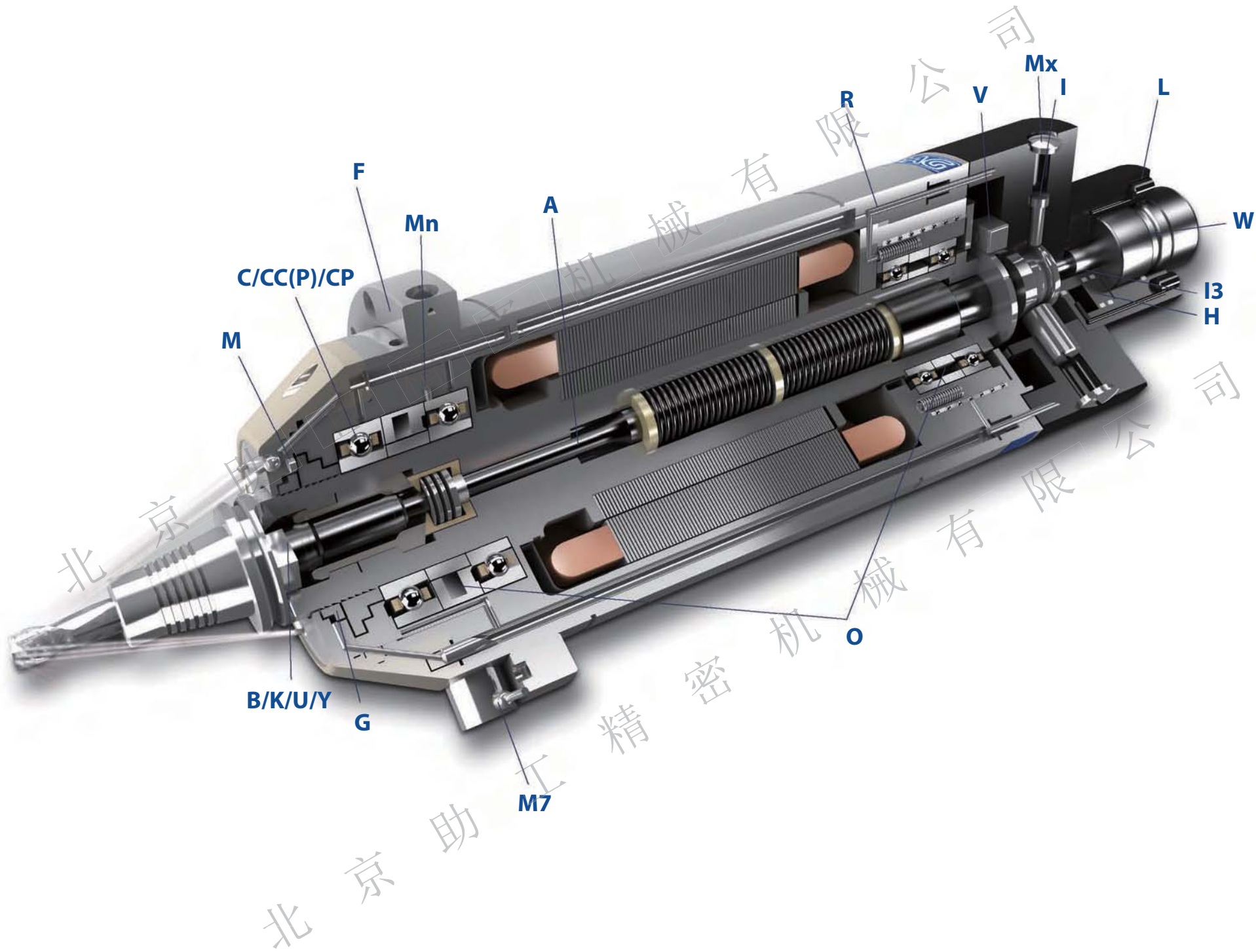

OPTIONS 可选项

BT/BBT/CAT/SK tooling system	B	BT/BBT/CAT/SK 刀具接口
Ceramic ball bearings	C	陶瓷球轴承
High speed ceramic ball bearings	CC	高速陶瓷球轴承
Spindle extension	E	电主轴加长
Flange according to spindle drawing	F	主轴法兰形式按用户要求
Antistatic brushes	G	抗静电刷
Tool change by hydraulic pressure	H	液压换刀
Sensors to check the tool holder position	I	拉刀状态检测传感器
Piston position monitoring	I3	松刀油缸活塞位置监测
HSK tooling system	K	HSK刀柄接口
Oil extraction system	L	回油机构
Spindle axial extension measurement	M	轴向热伸长检测
Bearing temperature sensor	Mn	轴承温度传感器
Datalogger	Mx	数据记录器
Vibration sensor	M7	振动传感器
Bearing arrangement for higher stiffness	O	高刚性轴承布置方式
Grease-packed ball bearings	P	预注脂球轴承
Hydraulic preload for higher axial load	R	可提供更大轴向载荷的液压预载
Special / customized solution	S	针对客户特殊要求设计
MEGA-xS tooling system	U	MEGA-xS刀柄接口
Encoder for vector control and shaft positioning	V	编码器用于主轴旋转矢量控制及准停
Tool cooling through spindle-centre	W	刀具中心出水冷却
Capto tooling system	Y	CAPTO 刀柄接口

北京助工精密机械有限公司

一个以专业高端产品服务于广大用户的公司；
一个“不断进取 精益求精”竭诚为您服务团队；
一个勇于创新，不断为您带来惊喜的合作伙伴。

北京助工 助您事业成功！

Engineering+
北京助工精密机械有限公司

机械附件铣头



IBAG
瑞士IBAG电主轴公司

电主轴



VOITH
德国Voith Turbo GmbH公司

端齿盘



VS Sensorik
德国VS Sensorik GmbH公司

编码器 传感器



北京助工精密机械有限公司

北京市宣武区广安门外南滨河路25号金工宏洋大厦B座421室

邮编：100055

电话：010-51920199 手机：13581835480

传真：010-51920200

邮箱：bjzgjm@126.com

网址：www.engineeringplus.cn